



SUMMER- 19 EXAMINATION

Subject - MANUFACTURING PROCESSES

Model Answer

Subject Code: **22446**

Important Instructions to examiners:

- 1) The answers should be examined by key words and not as word-to-word as given in the model answer scheme.
- 2) The model answer and the answer written by candidate may vary but the examiner may try to assess the understanding level of the candidate.
- 3) The language errors such as grammatical, spelling errors should not be given more Importance (Not applicable for subject English and Communication Skills).
- 4) While assessing figures, examiner may give credit for principal components indicated in the figure. The figures drawn by candidate and model answer may vary. The examiner may give credit for any equivalent figure drawn.
- 5) Credits may be given step wise for numerical problems. In some cases, the assumed constant values may vary and there may be some difference in the candidate's answers and model answer.
- 6) In case of some questions credit may be given by judgement on part of examiner of relevant answer based on candidate's understanding.
- 7) For programming language papers, credit may be given to any other program based on equivalent concept.

Q. No.	Sub Q N.	Answer	Marking Scheme
1	a	<p>List types of chips produced in machining process.</p> <p>The various types of chips produced in machining process are as follows:</p> <ol style="list-style-type: none"> 1. Continuous chips: According to its name, continuous chips have a continuous segment. . 2. Discontinuous chips or segmental chips: According to its name, this chips form in segment. 3. Continuous Chips with built up edge: This type of chip is same as the continuous chips except a built edge is form at the face of tool. 	<p>2 marks to list types</p>
	b	<p>List any four accessories used on lathe.</p> <p>The various accessories used in lathe are as follows.</p> <ol style="list-style-type: none"> 1) Lathe centers 2) Carriers or driving dog 3) catch plates 4) Chucks 5) Face plates 6) Angle plates 7) Mandrels 	<p>½ mark each for any four accessories</p> <p>2 marks</p>

OUR CENTERS :

KALYAN | DOMBIVLI | THANE | NERUL | DADAR
Contact - 9136008228



8) Rests		
c	Define Feed and speed in shaping machine 1) Feed: Feed (S) is the relative movement of the work or tool in a direction perpendicular to the axis of reciprocation of the ram per double stroke. It is expressed in mm per stroke. 2) Speed: In a shaper, the cutting speed is the speed at which the metal is removed by the cutting tool in a period of one minute.	1 mark for each definition 2 marks
d	List any four materials used for pattern making. The various types of materials used are as follows: <ol style="list-style-type: none">1. Wood2. Metal.3. Plastic.4. Plaster.5. Wax.	½ mark each for any 4 types 2 marks
e	List any four casting defects. The various types of casting defects are as follows: <ol style="list-style-type: none">1. Gas Porosity: Blowholes, open holes, pinholes.2. Shrinkage defects: shrinkage cavity.3. Mold material defects: Cut and washes, swell, drops, metal penetration, rat tail.4. Pouring metal defects: Cold shut, misrun, slag inclusion. Metallurgical defects: Hot tears, hot spot.	½ mark each for any 4 defects 2 marks
f	State the applications of rolling. Applications of rolling are as follows: <ol style="list-style-type: none">1. Concrete reinforcing bars.2. Plates.3. Wire rods.4. Sheet and strip.5. Rails.6. Piping and tubes.7. Body panels.8. Construction materials.	Any four application ½ mark each 2 marks
g	State the applications of TIG welding. The applications of TIG welding are as follows: <ol style="list-style-type: none">1. Mostly used to weld aluminum and aluminum alloys.2. It is used to weld stainless steel, carbon base alloy, copper base alloy, nickel base alloy etc.	2 marks Any Two application

OUR CENTERS :

KALYAN | DOMBIVLI | THANE | NERUL | DADAR
Contact - 9136008228



		<p>3. It is used to welding dissimilar metals.</p> <p>4. It is mostly used in aerospace industries.</p>											
2	a	<p>Write specifications of slotting machine.</p> <p>Specifications of a Slotter Slotter is generally specified in terms of the maximum length of the stroke.</p> <table border="0"> <tr> <td>1. Maximum stroke</td> <td>457 mm</td> </tr> <tr> <td>2. Diameter of rotary table</td> <td>915 mm</td> </tr> <tr> <td>3. Longitudinal movement</td> <td>762 mm</td> </tr> <tr> <td>4. Cross movement</td> <td>559 mm</td> </tr> <tr> <td>5. H.P. required</td> <td>7.5 HP</td> </tr> </table>	1. Maximum stroke	457 mm	2. Diameter of rotary table	915 mm	3. Longitudinal movement	762 mm	4. Cross movement	559 mm	5. H.P. required	7.5 HP	<p>Detailed specifications</p> <p>4 marks</p>
1. Maximum stroke	457 mm												
2. Diameter of rotary table	915 mm												
3. Longitudinal movement	762 mm												
4. Cross movement	559 mm												
5. H.P. required	7.5 HP												
	b	<p>Explain any four properties of Moulding sand.</p> <p>1. Porosity: Molten metal always contain a certain amount of dissolved gases, which are evolved when the metal freezes the molten metal coming in contact with the moist sand , generates steam or water vapour. If these gases and water vapour evolved by moulding sand do not find opportunity to escape completely through the mould they will form gas holes and pores in the casting. The sand must, therefore, be sufficiently porous to allow the gases or moisture present.</p> <p>2. Strength: This is the ability of sand particles to stick together. Insufficient strength may lead to a collapse in the mould or its partial destruction during conveying, turning over or closing. The mould may also be damaged during pouring by washing of the walls and core by the molten metal. The strength of moulding sand must, therefore, be sufficient to permit the mould to be formed to the desired shape and to retain this shape even after the hot metal is poured in the mould.</p> <p>3. Collapsibility: After the molten metal in the mould gets solidified, the sand mould must be collapsible so that free contraction of the metal occurs, and this would naturally avoid the tearing or cracking of the contracting metal.</p> <p>4. Adhesiveness: The sand particles must be capable of adhering to another body, i.e. they should cling to the sides of the moulding boxes. It is due to this property that the sand mass can be successfully held in a moulding box and it does not fall out of the box when it is removed.</p> <p>5. Cohesiveness: This is the ability of sand particles to stick together. Insufficient strength may lead to a collapse in the mould or its partial destruction during conveying, turning over or closing. The mould may also be damaged during pouring by washing of the walls and core by the molten metal. The strength of moulding sand must, therefore, be sufficient to permit the mould to be formed to the desired shape and to retain this shape even after the hot metal is poured in the mould.</p> <p>6. Refractoriness: The sand must be capable of withstanding the high temperature</p>	<p>Any 4 explanation</p> <p>1 mark each</p> <p>4 marks</p>										

OUR CENTERS :



of the molten metal without fusing. Moulding sands with a poor refractoriness may burn on to the casting. Refractoriness is measured by the sinter point of the sand rather than its melting

c Compare between Hot rolling and Cold rolling.

Sr No.	Hot rolling	Cold rolling
1	Metal is fed to the rolls after being heated above the recrystallization temperature.	Metal is fed to the rolls when it is below the recrystallization temperature.
2	In general rolled metal does not show work hardening effect.	The metal shows the working hardening effect after being cold rolled.
3	Co-efficient of friction between two rolls and the stock is higher; it may even caused shearing of the metal in contact with rolls.	Co-efficient of friction between two rolls and the stock is comparatively lower.
4	Experiment measurements are difficult to make.	Experiment measurement can be carried out easily in cold rolling.
5	Heavy reduction in area of the work piece can be obtained.	Heavy reduction is not possible.
6	Mechanical properties are improved by breaking cast structure are refining grain sizes below holes and others, similar deformation in ingot (get welded) and or removed the strength and the toughness of the job should increases.	Hotness increased excessive cold working greatness crackers ductility of metal reduction. Cold rolling increased the tensile strength and yield strength of the steel.
7	Rolls radius is generally larger in size.	Rolls radius is smaller.
8	Very thin sections are not obtained.	Thin sections are obtained.

Any 4 correct comparison
1 mark each
4 marks

OUR CENTERS :

		<p>9 Hot roll surface has (metal oxide) on it, this surface finish is not good.</p> <p>10 Hot rolling is used un ferrous as well as non ferrous metals such as industries for steel, aluminum, copper, brass, bronze, alloy to change ingot into slabs.</p> <p>11 Hot rolling is the father of the cold rolling.</p>	<p>The cold rolled surface is smooth and oxide free.</p> <p>Cold rolling is equally applicable to both plain and alloys steels and non ferrous metals and their alloys.</p> <p>Cold rolling follows the hot rolling.</p>	
	d	<p>Explain with neat sketch the working principle of MIG.</p> <p>In metal-arc inert gas welding the Weld area is shielded by an effectively inert atmosphere of argon, helium, carbon dioxide, or various other gas mixtures . The consumable bare Wire is fed automatically through a nozzle into the Weld arc by a Wire-feed drive motor . In addition to using inert shielding gases, deoxidizers usually are present in the electrode metal itself in order to prevent oxidation of the molten-weld puddle. Multiple-weld layers can be deposited at the joint.</p>	<p style="text-align: center;">Figure: Principle of MIG welding</p>	<p>2 marks for principle 2 marks for sketch</p>
3	a	<p>Single point Cutting tool signature</p> <p>The shape of a tool is specified in a special sequence and this special sequence is called tool signature. The tool signature is given below</p> <ul style="list-style-type: none"> (i) Back rake angle (ii) Side rake angle (iii) Clearance or End Relief angle (iv) Side Relief angle (v) End cutting edge angle (vi) Side cutting edge angle (vii) Nose radius 		<p>04 marks for correct explanation</p>

OUR CENTERS :

KALYAN | DOMBIVLI | THANE | NERUL | DADAR
Contact - 9136008228

A typical tool signature of single point cutting tool is 0-7-6-8-15-16-0.8. Here this tool signature indicates that the tool has 0, 7, 6, 8, 15, 16 degree back rake, side rake, end relief, side relief, end cutting edge, side cutting edge angle and 0.8 mm nose radius.

b Since useful work is done only during the forward stroke of ram, the mechanism driving the ram is so designed that the return stroke is completed in much less time than the forward stroke. The slotted lever quick return mechanism is illustrated in Figs. *a* and *b*. The crank *AB* (of adjustable length *R*) rotates with a uniform angular speed. The crank pin *B* is in the shape of a die block which is free to slide inside the slot in the slotted lever *OBC*. This slotted lever is pivoted at *O* and the other end *C* is connected to the ram by a short link arm as shown in Fig. (*a*). When the crank *AB* rotates clockwise from position *AB*₁ to *AB*₂, the ram moves forward from left to right and when it rotates from position *AB*₂ to *AB*₁ the ram returns back to its original position. Clearly the time taken to complete forward stroke is proportional to angle α (refer to Fig. (*b*)) and the return stroke is completed in less time which is proportional to angle β .

02 marks for sketch, 02 marks for explanation

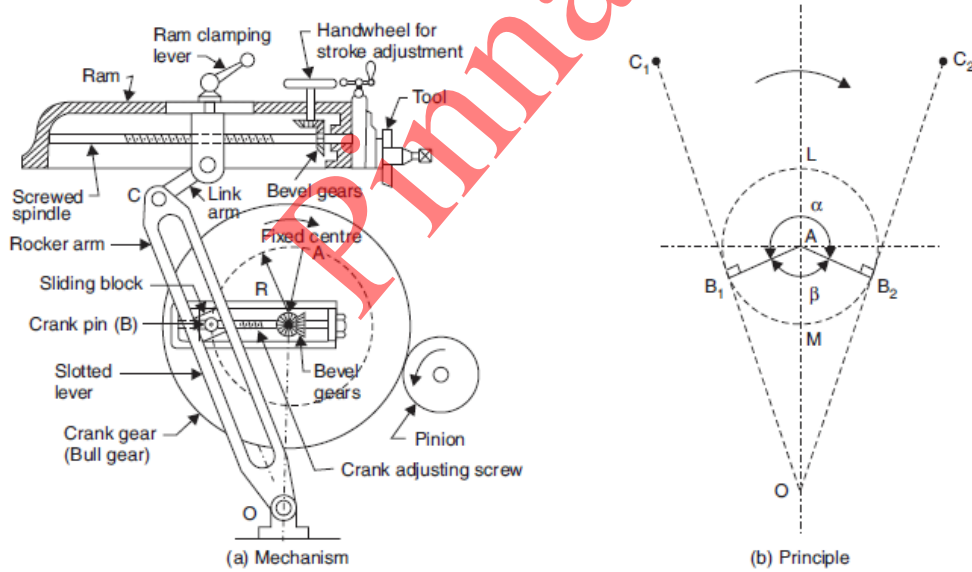

Fig. Quick return mechanism

c **Safety practices in foundry:**

1. Even trace amounts of MOISTURE and MOLTEN METAL don't mix; Steam explosions are the cause of death in foundries.
2. NEVER put water on a metal fire. This can cause a HUGE EXPLOSION
3. Have a DRY pile of sand and a shovel ready to put out fires or to control metal spills.
4. Have a sand bed under all areas. The sand bed should be at least 3 inches thick.

Any four points 01 mark each



- This will help in containing metal spills and will help protect flooring.
5. Never pour over wet ground. Remember, even TRACE AMOUNTS of MOISTURE can cause EXPLOSIONS.
 6. Molten metal spilled on concrete will cause the concrete to explode. Use a thick sand bed over concrete.
 7. Always use clean metal as feedstock. Combustion residues from some lubricants and paints can be very toxic.
 8. Always operate in a well-ventilated area. Fumes and dusts from combustion and other foundry chemicals, processes and metals can be toxic.
 9. Use a NIOSH rated dusk mask. Dusts from sand, parting dusts and chemicals can be hazardous or cancer causing. Protect your lungs.
 10. Wear safety gear, This includes, Leather shoes , Fireproof apron ,Foot and leg protection, Proper gloves, wire mesh face shield, Safety glasses , Cotton baseball hat.
 11. Never use a crucible that has been damaged or dropped. It's just not worth the risk. Imagine what would happen if a white-hot crucible of brass crumbled as you were carrying it.
 12. Always charge crucibles when cold. Adding metal to a hot crucible is really dangerous. If there is moisture on the metal, even just a haze, the metal can cause the entire contents of the crucible to explode.
 13. Spilled molten metal can travel for a great distance. Operate in a clear work area.
 14. use Long-handled pliers (or tongs) and rod. The pliers are designed for adding things to the crucible and adjusting coals, etc. The rod is used for mixing the contents of crucible and move dross to the side just before pouring.
 15. Think about what you are doing at all times. Focus on the job at hand and the next step. Have all moves planned and rehearsed prior to any operation.
 16. Educate yourself beforehand and always be careful of your own and bystander safety.

d **Differentiate between soldering and brazing**

S. No.	Soldering	Brazing
1.	It is used in electrical industries to joint capacitor, resistor, wire etc. to the electronic plate.	It is used to mechanical industries to joint different metals.
2.	Soldering is done at temperature below 200 C.	Brazing is done at temperature above 450C but below the critical temperature of metal.
3.	These joints are weaker than brazing joints.	It forms stronger joint.

An four points 01 mark each

OUR CENTERS :

KALYAN | DOMBIVLI | THANE | NERUL | DADAR

Contact - 9136008228

Page No: ____ / N

		<table border="1"> <tr> <td>4.</td> <td>In soldering an alloy of lead and tin is used known as solder.</td> <td>In brazing an alloy of copper and zinc is used as filler metal.</td> </tr> <tr> <td>5.</td> <td>It does not need a special training to soldering.</td> <td>It needs special trading.</td> </tr> <tr> <td>6.</td> <td>It is a cheaper process.</td> <td>It is a costly process.</td> </tr> <tr> <td>7.</td> <td>Soldering does not need to preheat of base metal.</td> <td>This process needs preheating of base metal.</td> </tr> <tr> <td>8.</td> <td>It is used to joint electronics component.</td> <td>It is used in automotive industries and pipe fitting.</td> </tr> <tr> <td>9.</td> <td>This process is very flexible and easy to automate.</td> <td>It is not so easy for automation except automation is done at automotive industries.</td> </tr> </table>	4.	In soldering an alloy of lead and tin is used known as solder.	In brazing an alloy of copper and zinc is used as filler metal.	5.	It does not need a special training to soldering.	It needs special trading.	6.	It is a cheaper process.	It is a costly process.	7.	Soldering does not need to preheat of base metal.	This process needs preheating of base metal.	8.	It is used to joint electronics component.	It is used in automotive industries and pipe fitting.	9.	This process is very flexible and easy to automate.	It is not so easy for automation except automation is done at automotive industries.	
4.	In soldering an alloy of lead and tin is used known as solder.	In brazing an alloy of copper and zinc is used as filler metal.																			
5.	It does not need a special training to soldering.	It needs special trading.																			
6.	It is a cheaper process.	It is a costly process.																			
7.	Soldering does not need to preheat of base metal.	This process needs preheating of base metal.																			
8.	It is used to joint electronics component.	It is used in automotive industries and pipe fitting.																			
9.	This process is very flexible and easy to automate.	It is not so easy for automation except automation is done at automotive industries.																			
4	a		02 marks for sketch, 02 marks for labeling																		
	b	<p>Types of slotting machine:-</p> <p>1. Puncher slotter 2. Precision slotter 3. Production slotter</p> <p>Working Principle of Slotting machine:-</p> <p>The slotting machine is a reciprocating machine tool in which, The vertical slide holding the cutting tool is reciprocated by a crank and connecting rod mechanism, The job, to be machined, is mounted directly or in a vice on the work table. Like shaping machine, in slotting machine also the fast cutting motion is imparted to the tool and the feed motions to the job. In slotting machine, in addition to the longitudinal and cross feeds, a rotary feed motion is also provided in the work table.</p>	02 marks for classification, 02 marks for principle																		
	c	<p>Injection Molding produces plastic parts by forcing molten material into a mold where it cools and hardens. The molded shape produced is a reverse image of the mold tool. Injection molding is low cost moulding for simple and complex parts. The pressure of injection is high, dependant on the material being processed.</p> <p>Injection Molding is commonly used for thermoplastics. The powder compound is first heated to drive moisture and then feed into the hopper. When the rain is drawn back, some of the powder drops into the chamber. Close the mold and ram is moved forward applying pressure behind the powder. This compresses the material and forces it forward through thin space left around the heated torpedo. The material will come in contact with heated source and solution. The material during heating in the chamber rises the temperature between 175⁰ c to 275⁰ c. This heated</p>	02 marks for sketch, 02 marks for explanation																		

material is forced into the mold then the mold is cooled and it is opened. The part is knocked out by knockout pins.

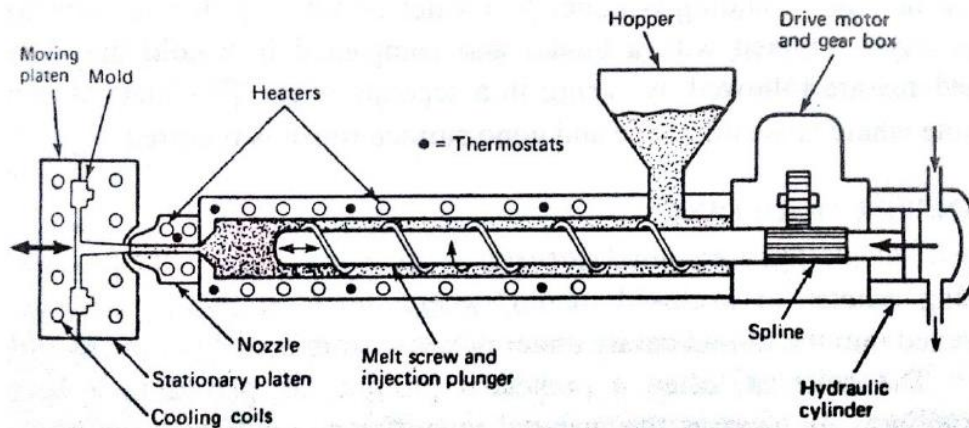

Figure: Injection Moulding

d **Types of rolling mills and its applications:-**

- (1) **Two-high rolling mill:** used in blooming and slabbing mills
- (2) **Three-high rolling mill:** used for making plates or sections.
- (3) **Four-high rolling mill:** It is used for both hot and cold rolling of wide plates and sheets.
- (4) **Cluster rolling mill:** This mill is used for rolling stainless steel and other high strength steel sheets of thin gauge.

02 marks for types any four (1/2 mark for each type,) 02 marks for application (1/2 mark each ,)

Pinnacle

e	Welding Defects		02 marks for list any four defects (1/2 mark each)02 marks for causes (1/2 mark each)
	Welding defects	Explanation and causes	
	1. Cracks	Cracks occur when localized stresses exceed the ultimate tensile strength of material. These stresses are developed due to shrinkage during solidification of weld metal. Cracks may be developed due to poor ductility of base metal, high sulphur and carbon contents, high arc travel speeds i.e. fast cooling rates, too concave or convex weld bead and high hydrogen contents in the weld metal.	
	2. Porosity	Porosity results when the gases are entrapped in the solidifying weld metal. These gases are generated from the flux or coating constituents of the electrode or shielding gases used during welding or from absorbed moisture in the coating. Rust, dust, oil and grease present on the surface of work pieces or on electrodes are also source of gases during welding.	
	3. Lack of Fusion	Too fast a travel, Incorrect welding technique, Insufficient heat	
	4.Slag Inclusion	Slag from previous runs not being cleaned away, Insufficient cleaning and preparation of the base metal before welding commences.	
5. Undercuts	Too fast a travel, Bad welding technique, Too great a heat build-up.		

5	a	<p>Explain with neat sketch following drilling operation:</p> <p>(i) Reaming</p> <p>The process of enlarging the hole is called reaming. A reamer is a type of rotary cutting tool used in metalworking. Precision reamers are designed to enlarge the size of a previously formed hole by a small amount but with a high degree of accuracy to leave smooth sides. There are also non-precision reamers which are used for more basic enlargement of holes or for removing burrs.</p> <div style="text-align: center;"> </div> <p>(ii) Boring operation:</p> <p>In machining, boring is the process of enlarging a hole that has already been drilled (or cast) by means of a single-point cutting tool, such as in boring a gun</p>	02 marks for each (01 Mark for description, 01 Mark for figure)
---	---	---	---

barrel or an engine cylinder. Boring is used to achieve greater accuracy of the diameter of a hole, and can be used to cut a tapered hole. Boring can be viewed as the internal-diameter counterpart to turning, which cuts external diameters.

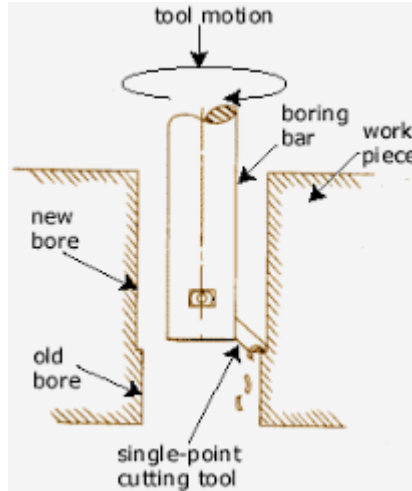

Boring operation

(iii) Counter sinking:

Countersinking is the operation of making a cone shaped enlargement of the end of a hole to provide a recess for a flat head or countersink rivet fitted into the hole. The tool used for countersinking is called a countersink. Standard countersinks have 60, 82 or 90 included angle and the cutting edges of the tool are formed at the conical surface.

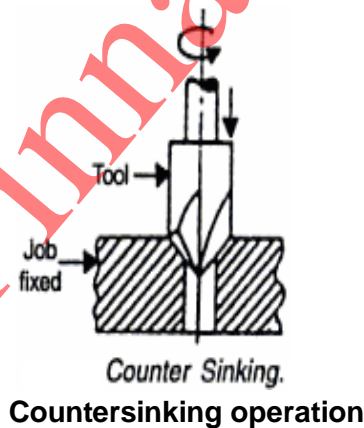

Countersinking operation

b Types of pattern:

1. Single piece pattern
2. Split pattern
3. Match plate pattern
4. Cope and drag pattern
5. Gated pattern
6. Loose piece pattern
7. Sweep pattern
8. Skeleton pattern
9. Segmental pattern
10. Shell pattern
11. Built up pattern

Any Six types
03 Marks (1/2
mark each), 3
marks for
procedure

OUR CENTERS :

KALYAN | DOMBIVLI | THANE | NERUL | DADAR
Contact - 9136008228

- 12. Boxed up pattern
- 13. Lagged up pattern
- 14. Left and right hand pattern

Procedure for Pattern Construction: The pattern part of casting process, it is replica of the object to cast, and used to prepare the mold cavity into molten material poured during the casting process. The sand casting pattern making is duplicate component of molding. The design patterns material such as wood, metal or plastic and more. The sand casting pattern making with same shape of part, not exactly in same size. Because of shrinkage provide when it convert from liquid form into solid state. So the cavity made in little large than the exact actual part required. There should be some of allowances with in machining and finishing process. It required to modification are addition of pattern allowances. If the hollow casting provided, the core are used to create the cavity in finished part. The quality of casting depends on the design patterns material and construction. Sweep pattern sand casting is mainly for circular part make.

c Types of Press Forging Operation:

1) Cold forging: Forging is carried out at or near room temperature (below the recrystallization temp.) of the metal. Carbon and standard alloy steels are most commonly cold forged. Cold forging is generally preferred when the metal is already a soft, like aluminum. This process is usually less expensive than hot forging and the end product requires little or no finishing work.

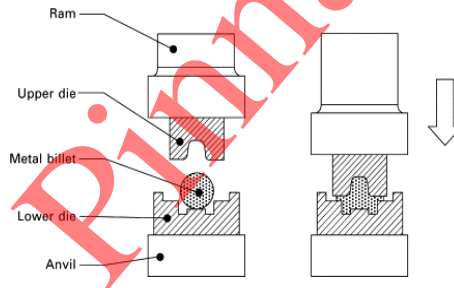

2) Hot forging: Forging is carried out at a temperature above the recrystallization temperature of the metal. The recrystallization temperature is defined as the temperature at which the new grains are formed in the metal. This kind of extreme heat is necessary in avoiding strain hardening of the metal during deformation.

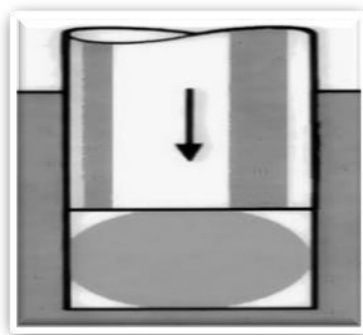

3) Closed-die forging : Forging in which the material is fully constrained in the cavity created by the upper and lower die halves. It allows more accurately shaped parts to

Any 3 , 02 marks each (01 mark for sketch 01 mark for explanation)

OUR CENTERS :

be formed, higher interface pressures required, Requires very accurate control of material volume and proper die design. Closed-die forging is a form of impression-die forging, which does not depend on flash formation to achieve complete filling of the die. Material is deformed in a cavity that allows little or no escape of excess material, thus placing greater demands on die design.

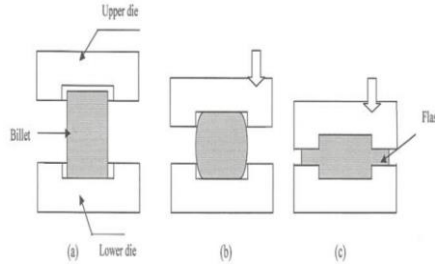

4) Open-die forging: Forging in which the flat dies of simple shape are used to allow the material to freely deformed in lateral directions of applied load. open die forging is only suitable for simple shapes for its less dimensional accuracy, there is high requires on the skill of operators, the dies of open die forgings are simple and less expensive, which is simplest of all the forging operations.

1. Open Die Forging

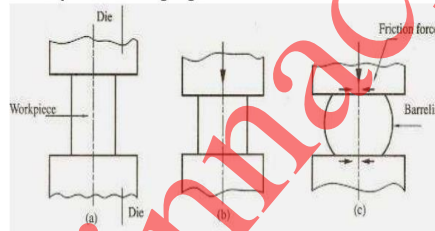

6	a	<p>Taper turning is performed, when a specific taper is required on work-piece. This can be performed by following four methods:</p> <ol style="list-style-type: none"> 1. Form tool method 2. Tail-stock set over method 3. Compound rest method 4. Taper turning attachment method <p>Explanation:</p> <p>1. Form tool method:</p> <p>This is one of the simplest methods to produce short taper. To the required angle the form is grounded and used. The tool is fed perpendicular to the lathe axis, when the work piece rotates.</p>
---	---	---

Types 02
Marks ½ mark
each(any four
types) , Any
one explain
04 Marks (02
marks for
sketch 02
marks for
explanation)

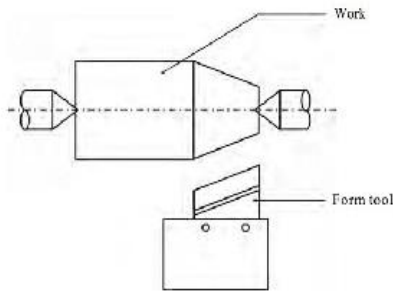

Taper turning by form tool method

3. Compound rest method:

Generally short and steep taper are produced using this method. In this method the work piece is held in the chuck and it will be rotated about the lathe axis. The compound rest is swiveled to the required angle and then it will be clamped in position.

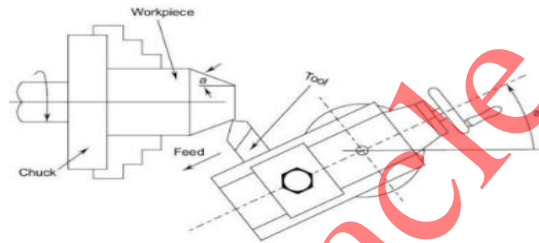

4. Taper turning attachment method:

In this method by using bottom plate or bracket, a taper turning attachment is attached to the rear end of the bed. It has a guiding bar which is usually pivoted as its center. The guiding bar has the ability to swing and it can be set in any required angle. It has graduations in degrees. It has a guide block which connects to the rear end of the cross slide and it moves on the guide bar. The binder screw is removed, before connecting the cross slide, hence the cross slide is free from the cross slide screw.

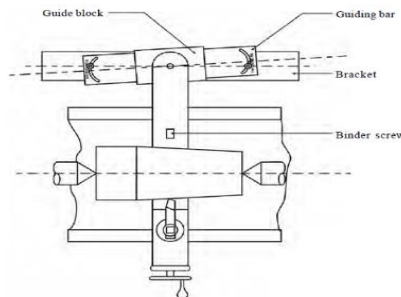

Taper turning by taper attachment method

b Calendaring Process of plastic manufacturing:

Calendaring is a process in which heat and pressure are applied to a fabric by passing it between heated rollers, imparting a flat, glossy, smooth surface. During calendaring process rolls of the materials are passed between several pairs of heated rollers, to give

3 Marks
Explanation,
03 marks Fig

shiny surface. Luster (i.e. finishing) increases when the degree of heat and pressure is increased. Calendaring is applied to fabrics in which a smooth, flat surface is desirable, such as most cotton. Many linens and silks and various man made fabrics. Calendaring is also used for polymer materials. Extruded PVC Sheets are produced by this method.

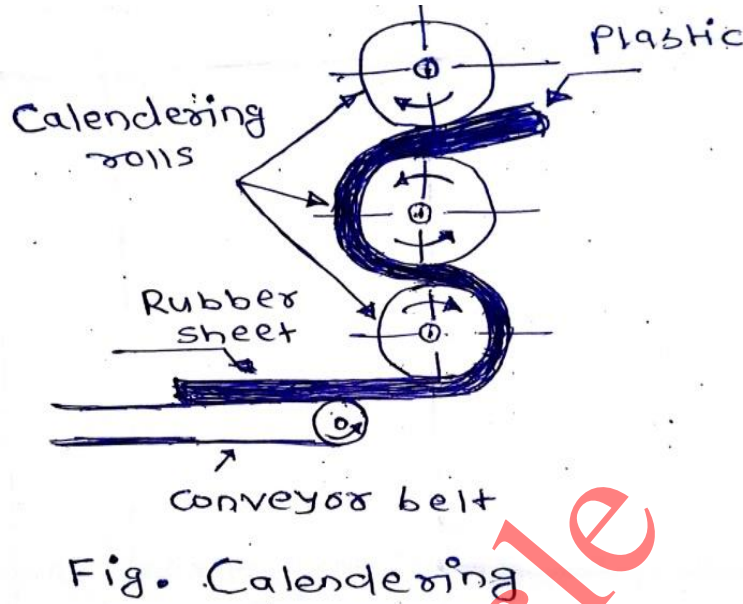

c **Direct Extrusion process:-**

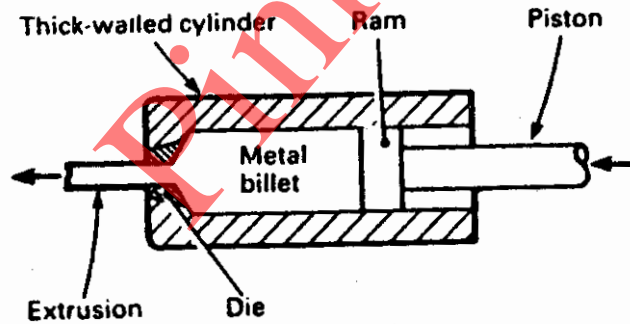

Direct extrusion

Direct extrusion process is shown in fig. The raw material used is a billet. It consists of a press operated ram and a cylinder or container into which the heated billet is placed. A dummy block is used between the ram and the hot metal. With application of ram pressure, the metal first plastically fills the cylindrical shape. And it is then forced out through the die opening until a small amount remains in the container.

Advantages of Direct Extrusion:-

- 1) close tolerance can be achieved with production of long shells
- 2) Direct extrusion can be employed for extruding solid circular or non-circular sections, hollow sections such as tubes or cups

Disadvantages of Direct Extrusion:-

- 1) Friction between the container and billet is high
- 2) greater forces are required

1 Mark for Explanation,
01 marks Fig

02 Marks for advantage
and 02 Marks for disadvantage

(Any two)

OUR CENTERS :



3) the corresponding extrusion pressure is also higher because of friction between container and billet.

Advantages of Indirect Extrusion:-

- 1) there is less friction between the container and billet.
- 2) Less forces are required for indirect extrusion.
- 3) Indirect extrusion can produce hollow (tubular) cross sections,

Disadvantages of Indirect Extrusion:-

- 1) Indirect extrusion cannot be used for extruding long extrudes.
- 2) Support of the ram becomes a problem as work length increases.

Pinnacle